

EX-ABSL-RC ANTISTATIC BAR



The **EX-ABSL-RC** is an antistatic bar with ATEX certification for use in hazardous areas.

The antistatic bar **EX-ABSL-RC** is designed to be installed in machines working at high speed, it is very effective in the removal of electrostatic charges.

This antistatic bar has a PVC core, where all its electronic components are impregnated in epoxy resin so as to ensure safety and durability. It is coated with aluminium, with stainless steel emitters.

The emitters are connected resistively to high voltage, so there are no risks for the operator in the event of accidental contact and this allows to have a higher productivity of the bar.

This antistatic bar has a slit where to place the M6 screws for fastening, so it is possible to place them anywhere for the entire length of the bar.

The power supply must be positioned outside of the hazardous area.

EX-ABSL-RC	
Certification	ATEX issued by TUV II 2G Ex mb IIB T6 Gb II 2D Ex mb IIIB T85°C Db
Working distance	20 - 200 mm
Operating voltage	7000 VAC
Power supply	APSX2 - APSX4
Weight	1.1 kg / m
Machine maximum speed	500 m / min
Ambient temperature	0° C - 70° C
Lengths	from 100 mm to 6000 mm

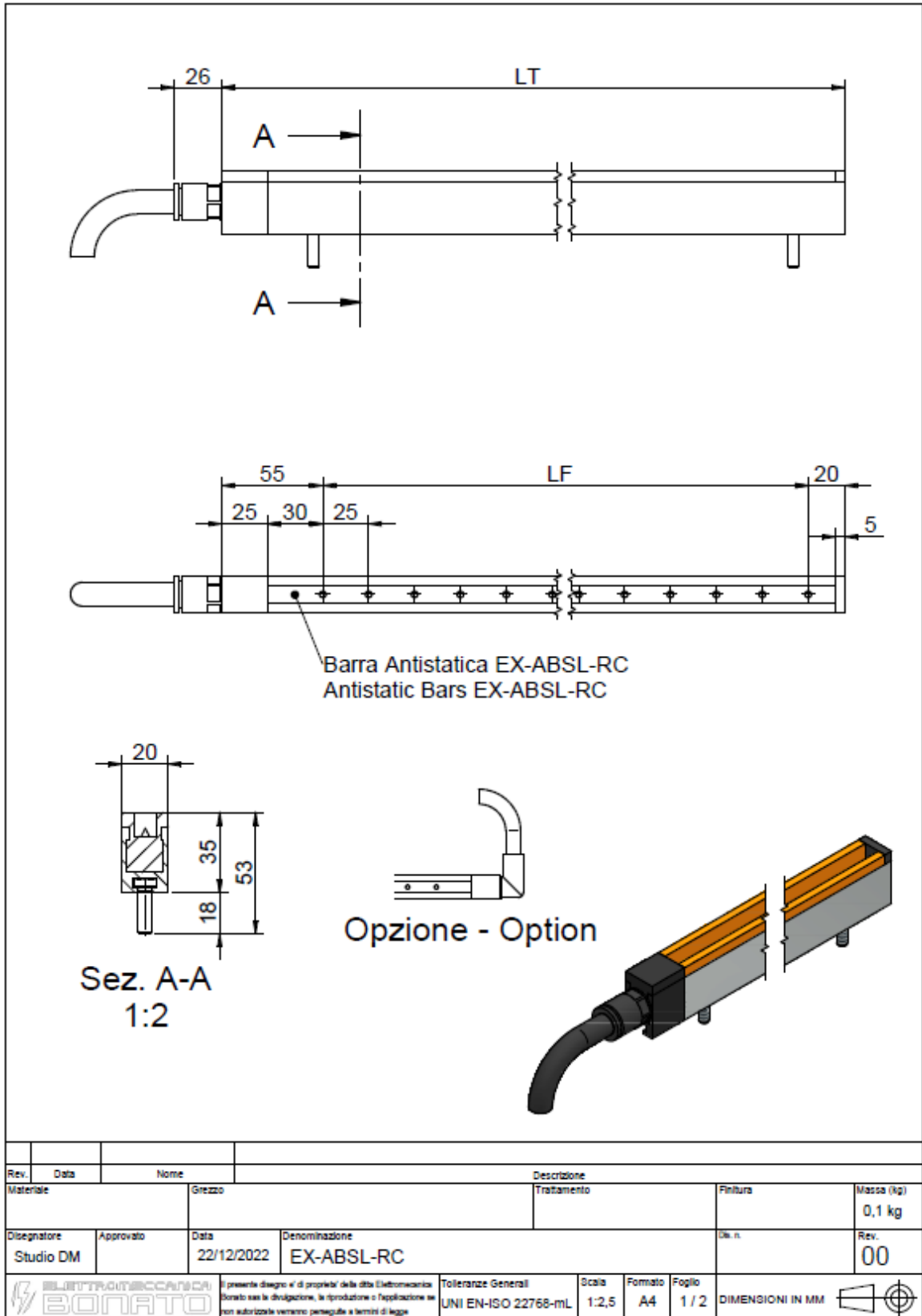

ELETTROMECCANICA BONATO

36010 Carré (Vicenza) ITALY - Via Rostoncello, 25/b T 0445 368178 - F 0445 364371
www.elettromeccanicabonato.it - info@elettromeccanicabonato.it

ANTISTATIC CONTROL SYSTEMS

