

ANTISTATIC BARS IDB-7



The Intelligent Discharging Bar **IDB-7** (shockless) we produce can be used in many sectors, such as textile manufacturing, paper, plastics, printing, in converting, packaging etc.

The antistatic bar **IDB-7** is designed to be installed in machines working at high speed, his design is very compact 40x25 mm and the profile is in FR-ABS filled with epoxy resin.

This antistatic bar has an integrated power supply, so no high tension cable is needed, only 12-24 V supply, the frequency is adjustable (0-20 Hz) and is provided with clean pin alert by a led and remote signal PNP and NPN.

Green/blue flashing= ok, Violet= needs cleaning, Red=fault.

The emitters (option tungsten) are connected resistively to high voltage, so there are no risks for the operator in the event of accidental contact.

Our antistatic bars are custom made according to customers' requirements.

This antistatic bar has a slit where to place the M5 screws for fastening, so it is possible to place them anywhere for the entire length of the bar.

IDB-7	
Working distance	20 - 200 mm
Operating voltage	7500 V pulsed
Frequency	Adjustable 0-20Hz or continuous
Power supply	Integrated 12-24 Vdc input, max. current 0.5A
Weight	1.2 kg / m
Machine maximum speed	500 m / min
Ambient temperature	0° C - 70° C, max humidity 65%
Lengths	from 250 mm to 5000 mm

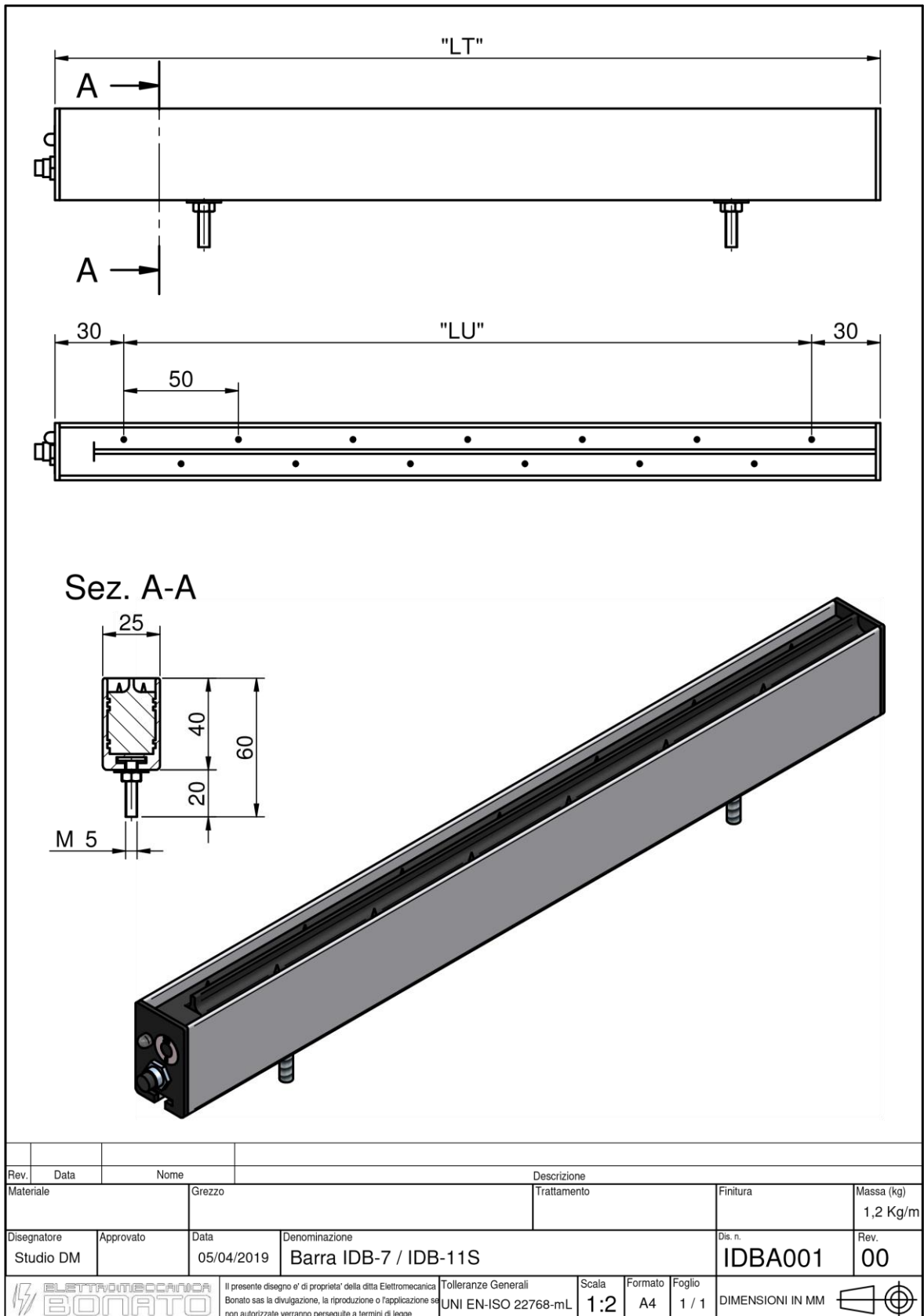

ELETTROMECCANICA BONATO

36010 Carré (Vicenza) ITALY - Via Rostoncello, 25/b T 0445 368178 - F 0445 364371
www.elettromeccanicabonato.it - info@elettromeccanicabonato.it